

DESCRIPTION

Water-cooled split yoke electromagnet for use with linear accelerator magnetron type MG6090.

GENERAL DATA

Electrical

The electromagnet contains two coils connected in series; these should be fed from a constant current power supply.

Maximum current.....	28	A
Maximum voltage.....	30	V
Typical conditions for 160 mT field:		
current.....	25	A
voltage (see notes 1 and 2).....	25	V

The DC electrical connections are made via 6 mm² flexible cables to screw clamps on the yoke (see outline).

Calibration

An individual calibration chart is supplied with each electromagnet (see below).

Cooling

MG6053 is water cooled via 1/4-inch BSP threaded connections, with a union coupling between the two halves of the cooling circuit (see note 3).

Minimum water flow required (see note 4).....	5.0	l./min
Inlet water temperature (see note 2).....	40	°C max

Mechanical

Overall dimensions	288 x 242 x 180 mm max
	11.339 x 9.528 x 7.087 inches max
Net weight.....	25 kg (55 pounds) approx

The electromagnet yoke is split with the bottom section hinged to allow insertion of the magnetron MG6090. The bottom section is normally clamped to the top section with four cap screws.

The electromagnet is mounted by means of holes, threaded M6, on each side of the top section of the yoke.

An A.F.C. mounting facility is provided by four threaded holes on the yoke.

NOTES

1. The field coil resistance increases after initial switch on, due to heating effects, necessitating an increase in voltage to maintain a constant current.
2. The field coil resistance varies with inlet water temperature.
3. When opening the yoke, disconnect the cooling pipe union between the two parts of the cooling circuit.
4. For a water flow of 5 l/min, a pressure of approximately 1.25 kg/cm² is required.

TYPICAL CALIBRATION CHART

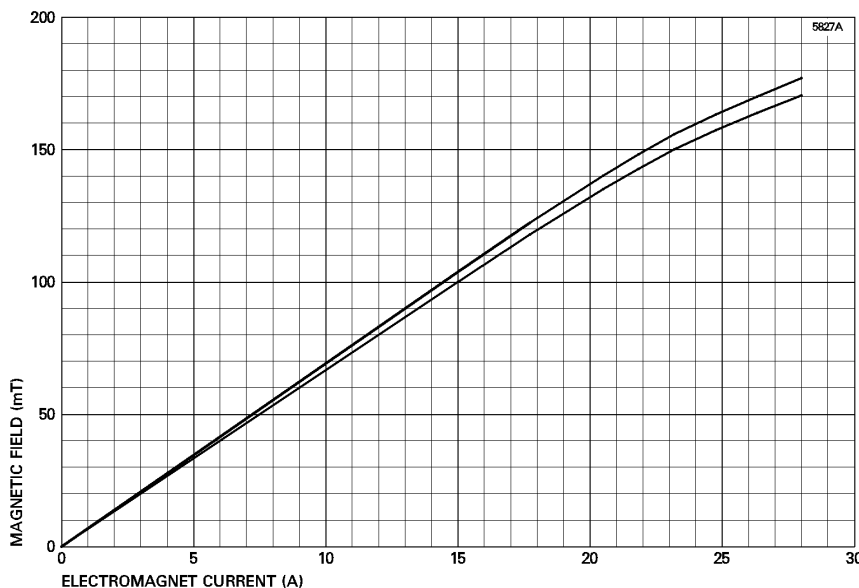

Whilst Teledyne e2v has taken care to ensure the accuracy of the information contained herein it accepts no responsibility for the consequences of any use thereof and also reserves the right to change the specification of goods without notice. Teledyne e2v accepts no liability beyond that set out in its standard conditions of sale in respect of infringement of third party patents arising from the use of tubes or other devices in accordance with information contained herein.

Teledyne e2v (UK) Limited, Waterhouse Lane, Chelmsford, Essex CM1 2QU United Kingdom Teledyne e2v (UK) Ltd. is a Teledyne Technologies company.
Telephone: +44 (0)1245 493493 Facsimile: +44 (0)1245 492492
Contact Teledyne e2v by e-mail: Enquiries@Teledyne-e2v.com or visit www.teledyne-e2v.com for global sales and operations centres.

OUTLINE (All dimensions in millimetres; dimensions without limits are nominal)

Ref	Millimetres
A	5.2
B	19.5
C	148.0 max
D	238.0
E	90.0
F	25.0
G	242.0 max
H	450.0 max
J	420.0 max
K	288.0 max
L	180.0 max
M	88.0 min

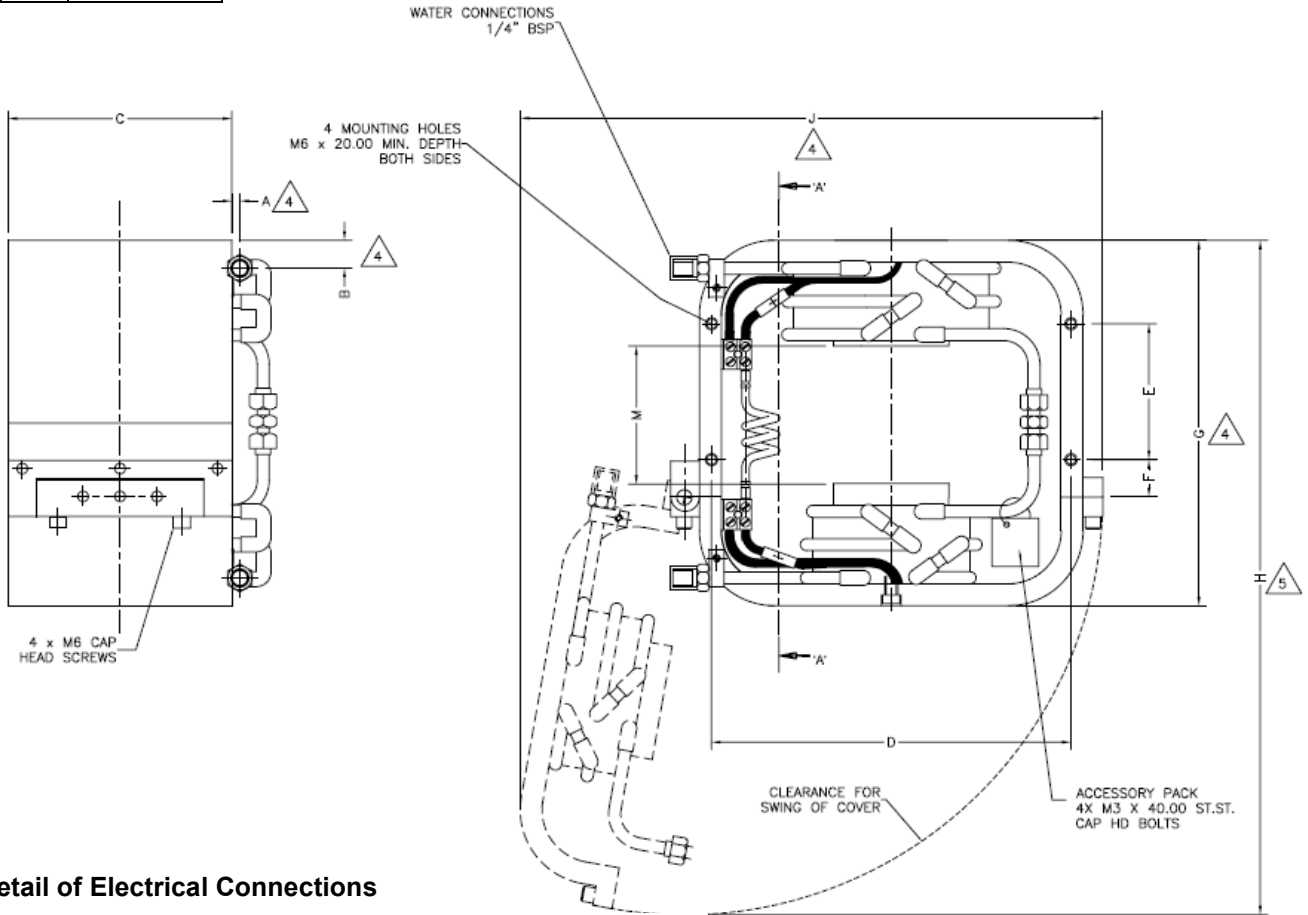
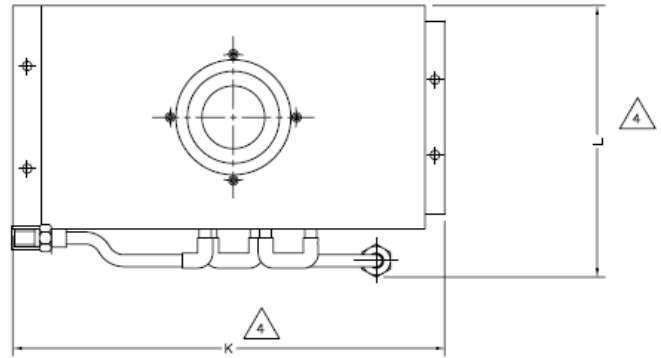

Detail of Electrical Connections

